

SEMI-AUTOMATIC PACHINKO MACHINE

OPERATING INSTRUCTIONS

IMPORTANT: Read carefully before use.



Pachinko  Palace Inc.

**3419 PACIFIC BLVD.
SAN MATEO, CALIF. 94403
(415) 341-4121**

SUMMARY OF INSTRUCTIONS

This Pachinko machine comes from a Pachinko parlor of Japan and has been completely rebuilt and checked out. It has been rough-framed so it can be played at once without further installation.

A. Object of Pachinko Game:

Using skill, propel steel balls into "pockets" for payoff—up to 15 balls. Pockets open and close as hit. Give all players the same number of balls to start game. Designate a time limit for each player and determine who has the most balls at the end of each period.

B. Face designs may vary on different games, but part identification remains the same.

Your Pachinko machine will give you many hours of enjoyment if you follow these simple instructions:

- (1) "WIN" POCKET
- (2) LOCK TAB (LOCATED BEHIND PLASTIC WINDOW DOOR)
- (3) PLAYING TRAY
- (4) FRONT COVER
- (5) PLASTIC WINDOW DOOR
- (6) BALL RETURN CHUTE
- (7) TRIP LEVER
- (8) SLIDE BAR
- (9) TRAY EMPTY LIGHT
- (10) TRAY EMPTY FLAG
- (11) PLAYING LEVER
- (12) FINGER REST BAR
- (13) RECEIVING TRAY

- 1.) Open window door by unlatching lever (16). Peel off plastic film from window (Key lock has been deactivated. There are no keys.)
- 2.) Before you feed balls into FEEDER TRAY (14) be sure that BALL DUMP LEVER (18) is closed (pushed to right in detent).
- 3.) Before machine is played, push RESET LEVER (19) up. Now Pachinko machine is in proper sequence.
- 4.) Place machine so that it stands upright on a level surface.
- 5.) Remove poly-bagged steel balls (300 pieces) from PLASTIC STORAGE TRAY (17) and load approximately 250 balls into FEEDER TRAY (14) and balance into PLAYING TRAY (3).
- 6.) Place empty PLASTIC STORAGE TRAY (17) at position (17) for receiving mis-balls. When PLASTIC STORAGE TRAY (17) becomes filled by mis-balls, load approximately one-half balls into FEEDER TRAY (14) and balance into PLAYING TRAY (3). Repeat procedure.
- 7.) To play, hold PLAYING LEVER (11) with thumb while grasping bar with forefinger. Snap release by sliding thumb to the right of lever.

CAUTION: Do not continue to flip balls when the Feeder Tray is empty. To prevent jamming, keep balls in the feeder tray for payoffs.

- 8.) Smooth operation helps control the ball and permits fast play. Skill can be developed by varying thumb pressure on the lever.
- 9.) To release balls from PLAYING TRAY (3), remove SLIDE BAR (8) right to left, then balls will fall into RECEIVING TRAY (13).
- 10.) Batteries are not shipped with Pachinko machines, but the game can be played without electric power. However, it is more exciting when the lights are operating.

WARNING: Do not attempt to modify for house current hookup. USE BATTERY ONLY.

FRONT

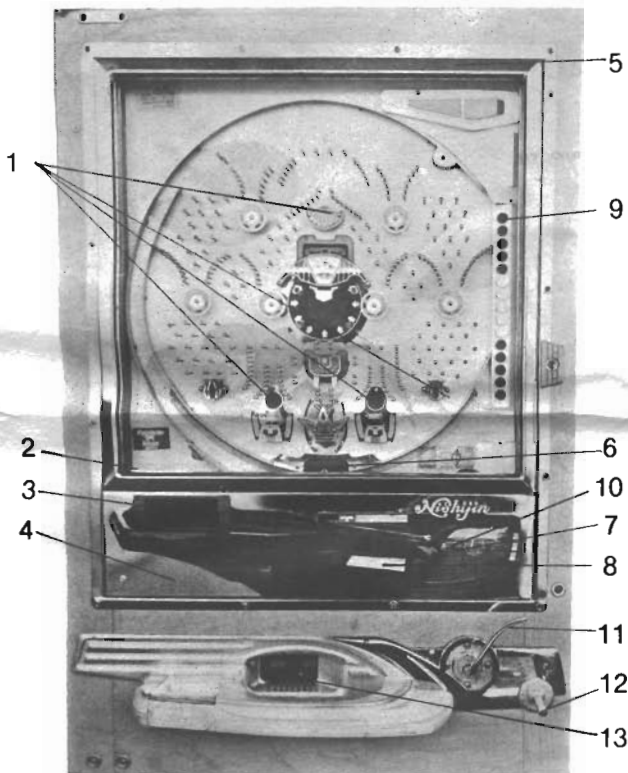

FIGURE 1

- (14) FEEDER TRAY
- (15) BATTERY PINS
- (16) PLASTIC WINDOW DOOR LOCKING LEVER
- (17) STEEL BALL PLASTIC STORAGE TRAY
- (18) BALL DUMP LEVER

- (19) RESET LEVER
- (20) WIN BALL EXIT CHUTE
- (21) LIGHT CONTACTS
- (22) WIRE RELEASE
- (23) PAYOFF LEVER

- (24) WIN STORAGE AREA
- (25) LIGHT COVER
- (26) LIGHT SOCKET

IMPORTANT: If the machine does not payoff when a "WIN" pocket is hit, it is not defective. It is an indication that there are no payoff balls in FEEDER TRAY (14). If you do jam the machine, please follow these simple instructions:

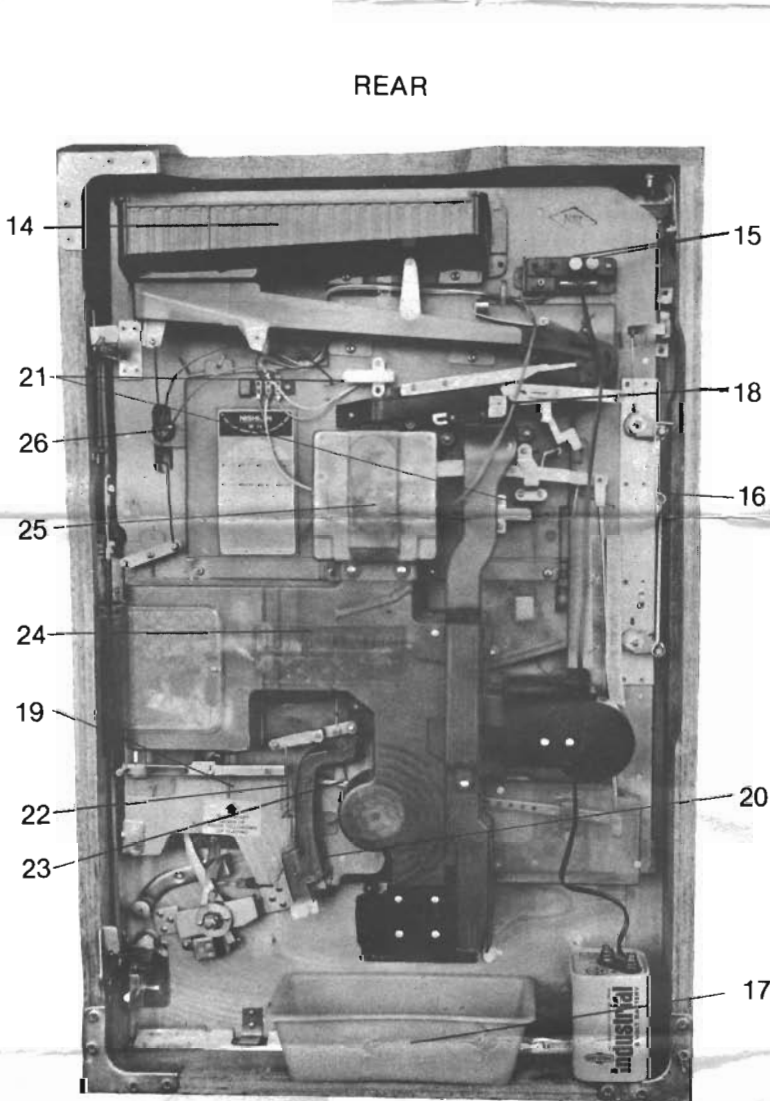

1.) Put at least 150 balls in TRAY (14).

2.) Make sure there are NO balls in CHUTE (20). If there are balls in this chute, they must be removed by lifting up WIRE (22), and pushing down on LEVER (23). The balls will release easier if CHUTE (20) is tapped lightly. See diagram below.

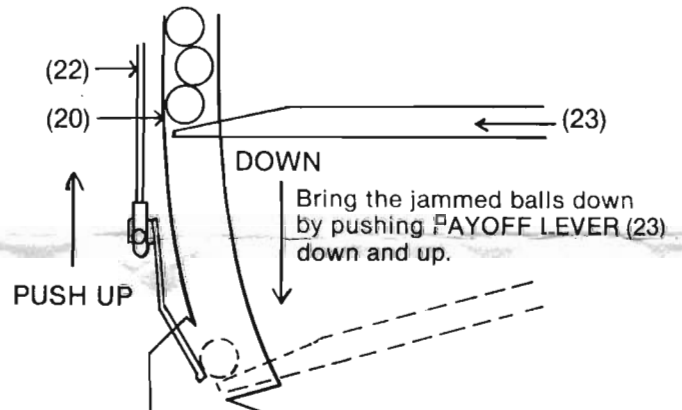

3.) Once you have removed all the balls from EXIT CHUTE (20), push the RESET LEVER (19) up, and the machine will automatically pay off all the win balls you have jammed in the WIN STORAGE AREA.

If the machine is played for a long period of time with no balls in the FEEDER TRAY (14), it may become necessary to tilt the machine from side to side, tapping firmly on STORAGE AREA (24). This will clear the jammed balls. Repeat steps 1, 2 and 3 until the jam has been cleared.

FIGURE 2

NOTE: Do not play with rusted or dirty Pachinko balls. Remove them from the machine by moving BALL DUMP LEVER (18) to the left. The balls remaining in the jackpot area may be removed by pulling the PAYOFF LEVER (23) down at the same time. The balls may then be cleaned by shaking them in a heavy sock.

ATTENTION: On super models, the TRAY EMPTY LIGHT is in the upper left hand corner. If this comes on and the tray empty flag is down, this is an indication that FEEDER TRAY 14 is empty and your machine will not flip balls. Please fill FEEDER TRAY #14.

TROUBLE SHOOTING AND SERVICING PROCEDURES

- 1.) IF A BALL EVER GETS STUCK IN A Butterfly win hole, remove the ball and use a screwdriver to enlarge the prongs inside the Butterfly.
- 2.) If balls will not stay in the rear of the machine, slide the pink tab on the BALL DUMP LEVER (18) to the right. See diagram below.

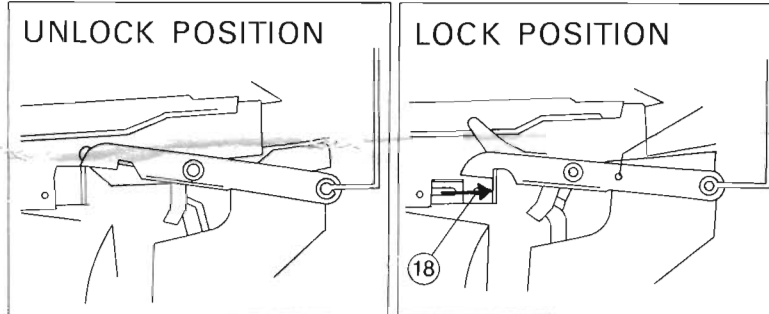

ARROW DIRECTION TO LOCK
To lock slide BALL DUMP LEVER (18) to the right
Unlock position empties balls into STORAGE BUCKET (17).

- 3.) In the event the center jackpot light does not light when you get a ball in the win hole, or the TRAY EMPTY LIGHT (9) does not light when the machine is empty, check the following:
 - a. Check both the battery and the wire connections for good electrical continuity.
 - b. The battery pin fuse may be bad, check and replace with fuse or aluminum foil.
 - c. Check for loose or burned out light bulbs in the light sockets and replace with 6 volt lantern bulb.
 - d. Check to see that LIGHT CONTACTS (21) are touching and are not corroded or bent. Clean and bend the copper contacts as required.
- 4.) To clean inside of PLASTIC WINDOW DOOR (5), lift up LOCKING LEVER (16) at the rear side of machine and gently open the PLASTIC WINDOW DOOR (5).
- 5.) To open LOWER FRONT COVER (4), push down LOCK TAB (2), which is located behind PLASTIC WINDOW DOOR (5). Pull hinged LOWER FRONT COVER (4) forward towards you to clean and inspect flow of balls to TRIP LEVER (7). This inner ball track is easily clogged by rug fuzz and dog hairs, so keep it clear, to insure trouble free service.

OPTIONAL ACCESSORY KIT

AN ACCESSORY KIT IS AVAILABLE. With this installation, your Pachinko lights will be activated. Kit consists of:

- a. 6 volt battery
- b. two 6 volt bulbs
- c. one 28 inch wire
- d. 100 steel Pachinko balls

To install the light bulbs, remove the 3 screws on LIGHT COVER (25), remove cover, and replace the large bulb. Remove LIGHT SOCKET (26) and replace bulb. Place battery in position in Figure 2 and hook wire from both terminals to BATTERY PINS (15).

Pachinko Palace or Pachinko House will assist you with any questions you may have with your unit.

LOCATIONS: California—Sacramento, San Mateo, San Diego, Canoga Park.
Florida—Miami
Opening Soon in Atlanta, Ga. and Dallas, Texas.